

# 7SG163 Ohmega 300 Series

7SG163 Protection Relay

## Document Release History

This document is issue 2010/02. The list of revisions up to and including this issue is:  
Pre release

2010/02	Document reformat due to rebrand

The copyright and other intellectual property rights in this document, and in any model or article produced from it (and including any registered or unregistered design rights) are the property of Siemens Protection Devices Limited. No part of this document shall be reproduced or modified or stored in another form, in any data retrieval system, without the permission of Siemens Protection Devices Limited, nor shall any model or article be reproduced from this document unless Siemens Protection Devices Limited consent.

While the information and guidance given in this document is believed to be correct, no liability shall be accepted for any loss or damage caused by any error or omission, whether such error or omission is the result of negligence or any other cause. Any and all such liability is disclaimed.

## Contents

1	Basic Schemes.....	3
1.1	Time Stepped Distance.....	3
1.2	Loss of Load.....	4
1.3	Reach Extension (Some models only).....	5
2	Schemes Incorporating a Signalling Channel.....	7
2.1	Permissive Underreach.....	7
2.2	Permissive Overreach Zone 1 – POR1.....	9
2.3	Permissive Overreach Zone 2 – POR2.....	10
2.4	Blocked Overreach (Some models only).....	12
2.5	Acceleration.....	13

# 1 Basic Schemes

## 1.1 Time Stepped Distance.

### 1.1.1 Scheme Operation

A TIME-STEPPED DISTANCE scheme is normally applied when there is no signalling available between relays. Generally, the Zone 1 elements are set to operate for faults up to 80% of the line length. The Zone 2 elements operate up to 120% of the line length after a time delay. The Zone 3 elements are set with a longer reach than the Zone 2 elements, and often have a degree of reverse reach (i.e. an offset characteristic) to provide a further level of back up protection. The Zone 3 time delay is set to be longer than the Zone 2 time delay.

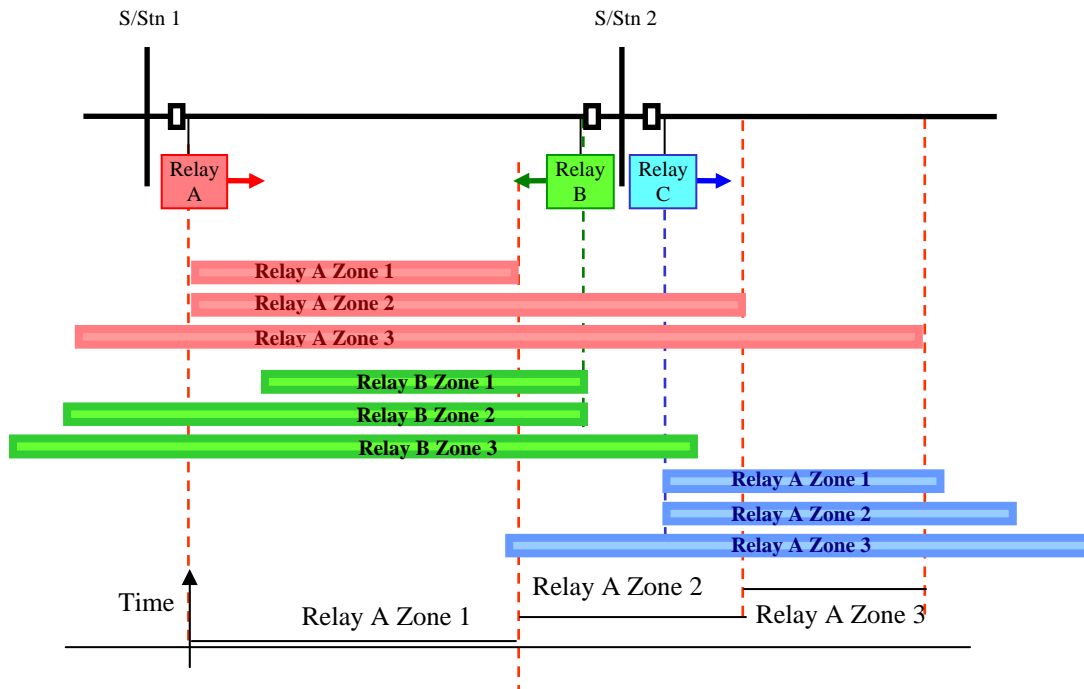

The disadvantage of such a scheme is that faults in the last 20% of the line are cleared after the Zone 2 time delay. This may be acceptable for lower voltage distribution systems, but for important circuits or higher voltage systems additional schemes are available to improve the tripping of the relay.

### 1.1.2 Settings

*Distance Scheme*

TIME-STEPPED

Status Inputs: N/A  
Relay Outputs: N/A

## 1.2 Loss of Load.

### 1.2.1 Scheme Operation

The Loss of Load protection scheme is used to give faster fault clearance time for an end zone fault (i.e between the Zone 1 boundary and the line end) when there is no signalling channel available. This allows a faster clearance time than the time-delayed Zone 2 elements.

Consider a fault occurring near to the remote end, i.e outside of the Zone 1 reach, but within the line length. In a normal time stepped distance scheme, the remote end relay would trip in Zone 1 time, and the local end relay would trip after the Zone 2 time delay. The Loss of Load scheme monitors the current in the healthy phases and can remove the Zone 2 time delay, speeding up the local end trip, when the remote end trip occurs.

If the relay detects a drop in current in one or two phases below the *Loss of Load Level*, with the current on the remaining phases above this level, it will remove the time delay from zone 2, for a fixed time delay (the *LOL Time Limit*) to allow the relay to trip instantaneously. This will allow the relay to trip more quickly for single or double phase faults, but will not affect operation for three phase faults.

A short time delay (typically 20ms), known as the *Loss of Load Pole Scatter Delay* or the *LOL CB Op Delay* is introduced to prevent the Loss of Load feature picking up during normal breaker operation.

### 1.2.2 Settings

The Loss Of Load function (LOL) is made active by selecting the scheme in the scheme selection menu. If a conventional scheme is selected and a communications failure occurs then a group setting change could be used to switch the scheme on until the communications is restored.

<i>Distance Scheme</i>	<b>LOSS OF LOAD</b>
<i>LOL Level</i>	0.1..0.9 <b>(0.5x In)</b>
<i>LOL CB Op Delay or LOL Pole Scatter Delay</i>	0..50 <b>(20ms)</b>
<i>LOL Time Limit</i>	0..60000 <b>(40ms)</b>

Status Inputs: N/A  
Relay Outputs: **AIDED TRIP, LOSS OF LOAD**

## 1.3 Reach Extension (Some models only).

This scheme is only available in relays with built-in autoreclose.

### 1.3.1 Scheme Operation

The Reach Extension is designed to be used in conjunction with an autoreclose system.

The Zone 1 elements within the relay have two settings. The standard Zone 1 settings are set as for the time-stepped distance scheme (i.e. 80% of the total line length). Zone 1 X settings are set to overreach the line length (usually these are set to the same value as the zone 2 setting)

When the reach extension scheme is implemented, the relay will use the extended zone 1 reach for tripping. The relay will trip and attempt to auto-reclose. After the CB has tripped and reclosed, the relay will use the standard (underreaching) Zone 1 reach for tripping. Consider a transient fault (i.e. a fault which is removed by tripping and auto-reclosing) in the last 20 % of the line, as shown in the diagram below. The overreaching Zone 1 will trip and reclose for this fault, and since it is transient, it will be cleared. A permanent fault will be cleared after the Zone 2 time on the second trip. Since the majority of faults are transient in nature, this will allow transient faults to be cleared more quickly.

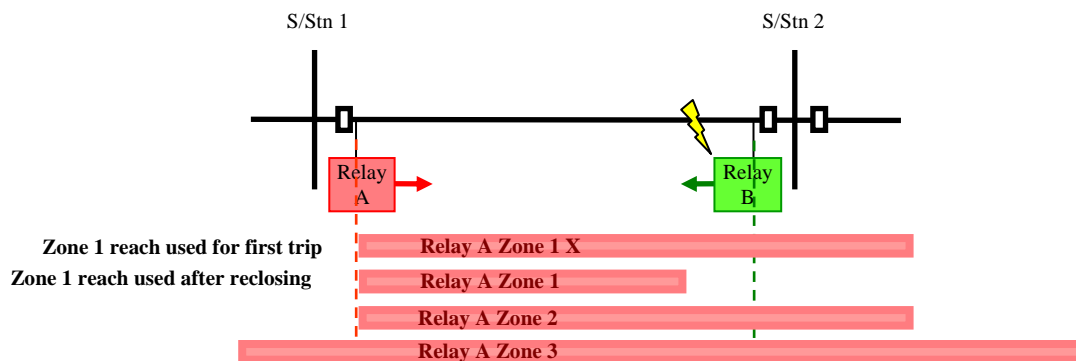

The disadvantage of this scheme is that since the extended Zone 1 reach is an overreaching Zone, it may operate for faults in the next line section. However, when the relay has reclosed, the Zone 1 reach will be reduced so the relay will trip after the Zone 2 time, allowing the correct relay to trip in Zone 1 after reclosing, if the fault is permanent. Overall this will increase the amount of circuit breaker operations on the system, and thus the amount of circuit breaker maintenance required, but it will improve clearance of transient faults

When a status input assigned *Block Reach Extension* is energised will the relay will use the normal Zone 1 reach.

The extended zone 1 reach will be active regardless of whether the autorecloser is on or out of service. It is advised that the *Block Reach Extension* status input is energised whenever the autorecloser is out of service. If the relay features an internal autorecloser, a normally closed contact should be assigned to Autorecloser in Service and connected back into the "Block Reach Extension" status input.

### 1.3.2 Settings

*Distance Scheme*

*Z1 Extension*

*Zone 1 X PF Impedance Reach*

*Zone 1 X PF Resistance Reach*

*Zone 1 X PF Reactance Reach*

*Zone 1 X EF Impedance Reach*

*Zone 1 X EF Resistance Reach*

*Zone 1 X EF Reactance Reach*

**REACH EXTENSION  
ENABLED**

These are the settings used by the relay for the first trip

Status Inputs: **BLOCK REACH EXT.**

Relay Outputs: N/A

## 2 Schemes Incorporating a Signalling Channel

Where a signalling channel is available between ends, the coverage of the relays can be improved. When these Protection Schemes are used, the Zone 1, 2 and 3 are arranged to trip as in the time stepped distance scheme. In addition to this, the relay is also capable of carrying out what is known as a “Carrier Aided Trip”, where the time delay on one of the Zones is removed when the conditions at the remote end, as indicated by the signalling channel meet certain criteria.

The distance protection signalling schemes use the relay outputs *Signal Send 1* and status input *Signal Received 1* for the signalling channel. It is possible to configure these channels with delay using the settings SS pickup, SS Dropoff and SR Dropoff.

### 2.1 Permissive Underreach.

#### 2.1.1 Scheme Operation

Typically (as for the time stepped scheme) the Zone 1 is set to 80% of the line length, Zone 2 to 120% of the line length and Zone 3 as delayed back up protection to cover at least the longest adjacent line.

The fault must be in the zone between the two relays (i.e. on the line section) if;

- Both Local and Remote Zone 1 elements operate, or
- Remote end Zone 1 operates AND local Zone 3 element operates.

This is shown in the diagram below:

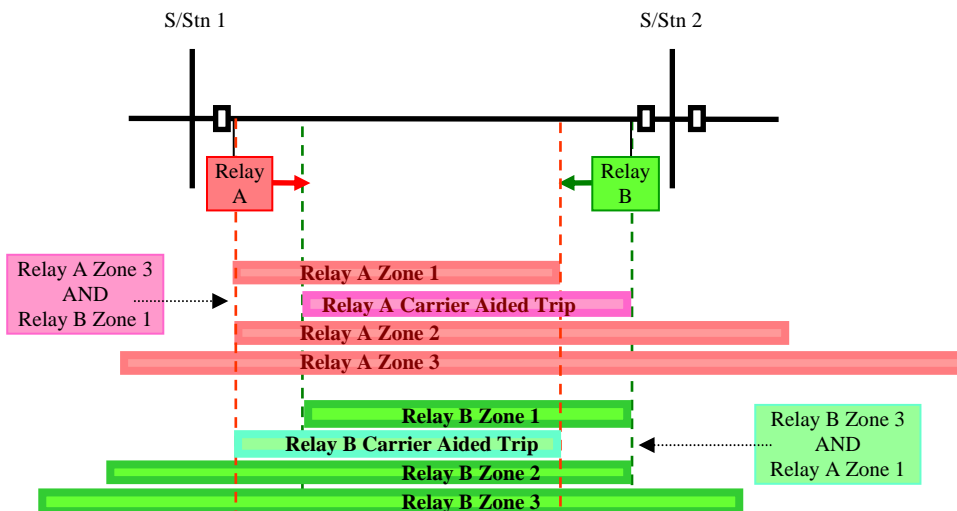

The relay is arranged to send a signal when its Zone 1 picks up.

The relay will trip instantaneously for a Zone 1 fault. If a signal is received from the remote end, the time delay will be removed from the Zone 3 element, allowing it to trip instantaneously. The name of the scheme comes from the fact that a Permissive signal is being sent by the Underreaching Zone 1.

Where the signalling equipment has an output which indicates that the signalling channel is out of service, this can be connected to a Status Input called *Carrier Recv Guard*. On energisation of this status input the relay will revert to a time stepped distance scheme.

## 2.1.2 Settings.

<i>Distance Scheme</i>	<b>PUR</b>
<i>SS Dropoff</i>	0..60000 (1ms)
<i>SR Dropoff</i>	0..60000 (1ms)

Status Inputs: **CARRIER RECV GUARD, SIGNAL RECEIVE 1**

Relay Outputs: **AIDED TRIP, SIGNAL SEND 1**



## 2.2 Permissive Overreach Zone 1 – POR1.

### 2.2.1 Scheme Operation

This scheme differs from the other relay schemes, in that it requires that the Zone 1 element to be set with a time delay. Typically the Zone 1 is set to 120% of the line length, Zone 2 to 120% of the line length and Zone 3 as delayed back up protection to cover at least the longest adjacent line. The Zone 1 time delay is usually set the same as the Zone 2 time delay.

The Zone 1 elements are arranged to overreach and the relay is arranged to send a Permissive signal send when any Overreaching Zone 1 element operates. When a signal is received from the remote end the relay will remove the Zone 1 time delay allowing the relays at both ends of the line to trip after a small time delay for an in-zone fault. Relay operation can be seen the diagram below;

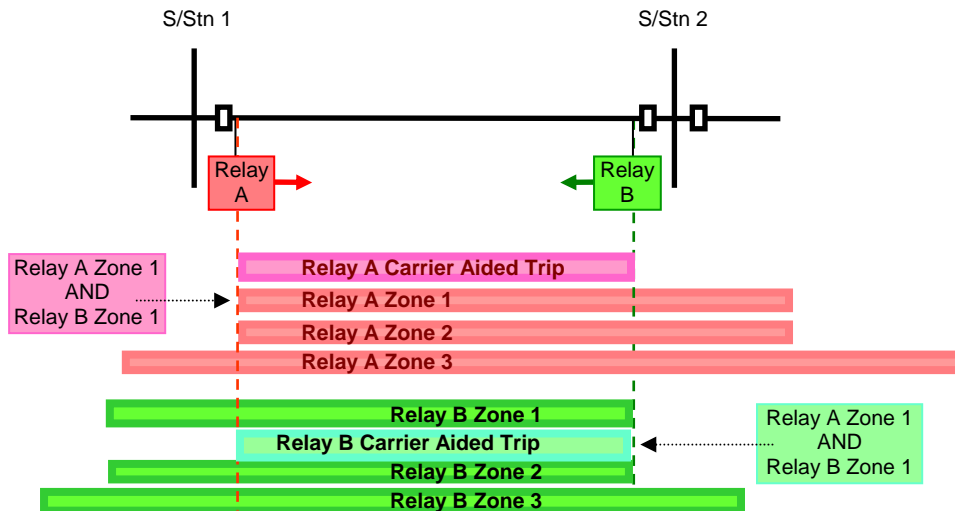

Where the signalling equipment has an output which indicates that the signalling channel is out of service, this can be connected to a Status Input called *Carrier Recv Guard*. On energisation of this status input the relay will revert to a time stepped distance scheme.

### 2.2.2 Weak End Infeed

If one end of the line has little or no source of fault current, the Relay may not see enough current for any of its Zones to pick up. However a Weak Infeed trip will be forced if;

- No Distance elements have picked up AND
- A permissive signal is received from the remote end AND
- There is a residual voltage present AND
- The local CB is closed.

### 2.2.3 Settings

<i>Distance Scheme</i>	<b>POR1</b>
<i>SS Dropoff</i>	0..60000 ( <b>1ms</b> )
<i>SR Dropoff</i>	0..60000 ( <b>1ms</b> )
<i>POR Weak Infeed Tripping</i>	Enabled/ <b>Disabled</b>
<i>POR Current Rev Reset</i>	0..60000 ( <b>200ms</b> )
<i>POR CB Echo Pulse</i>	0..60000 ( <b>250ms</b> )

Status Inputs: **CARRIER RECV GUARD, SIGNAL RECEIVE 1**

Relay Outputs: **AIDED TRIP, SIGNAL SEND 1, POR WEAK INFEED**

## 2.3 Permissive Overreach Zone 2 – POR2.

### 2.3.1 Scheme Operation

Typically (as for the time stepped and PUR schemes) the Zone 1 is set to 80% of the line length, Zone 2 to 120% of the line length and Zone 3 as delayed back up protection to cover at least the longest adjacent line. Zone 1 has no time delay, Zone 2 has a time delay, and the Zone 3 has a larger time delay.

The fault must be in the region between the two relays (i.e. on the line section) if;  
Zone 1 element operates, or

Remote end Zone 2 operates AND local Zone 2 element operates.

This is shown in the diagram below:

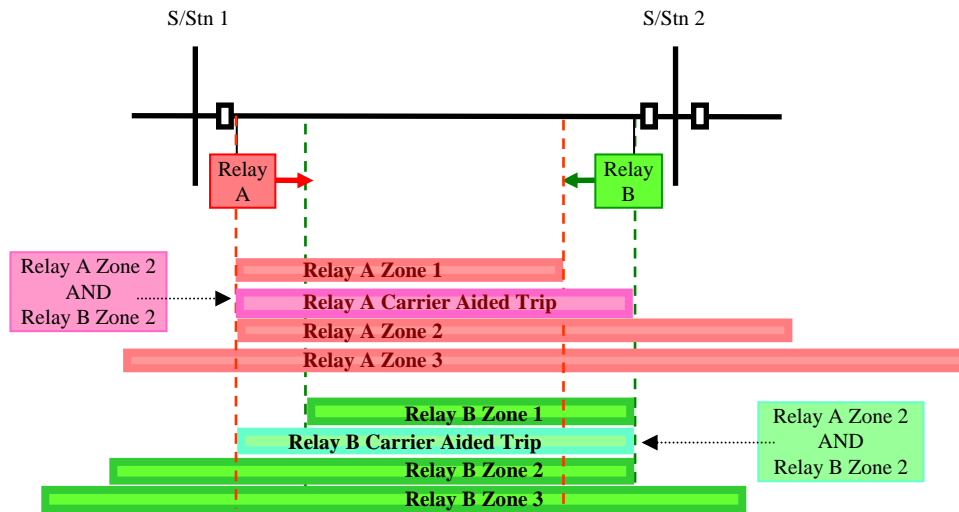

The relay is arranged to send a signal when its Zone 2 picks up.

The relay will trip instantaneously for a Zone 1 fault. If a signal is received from the remote end, the time delay will be removed from the Zone 2 element, allowing it to trip instantaneously. The name of the scheme comes from the fact that a Permissive signal is being sent by the Overreaching Zone 2.

This scheme may be used if the Zone 1 reach does not give sufficient resistive coverage, and may be useful on short lines.

Where the signalling equipment has an output which indicates that the signalling channel is out of service, this can be connected to a Status Input called *Carrier Recv Guard*. On energisation of this status input the relay will revert to a time stepped distance scheme.

### 2.3.2 Weak End Infeed

If one end of the line has little or no source of fault current, the Relay may not see enough current for any of its Zones to pick up. However a Weak Infeed trip will be forced if;

- No Distance elements have picked up AND
- A permissive signal is received from the remote end AND
- There is a residual voltage present AND
- The local CB is closed.

### 2.3.3 Settings

<i>Distance Scheme</i>	<b>POR2</b>
<i>SS Dropoff</i>	0..60000 <b>(1ms)</b>
<i>SR Dropoff</i>	0..60000 <b>(1ms)</b>
<i>POR Weak Infeed Tripping</i>	Enabled/ <b>Disabled</b>
<i>POR Current Rev Reset</i>	0..60000 <b>(200ms)</b>
<i>POR CB Echo Pulse</i>	0..60000 <b>(250ms)</b>

Status Inputs: **CARRIER RECV GUARD, SIGNAL RECEIVE 1**

Relay Outputs: **AIDED TRIP, SIGNAL SEND 1, POR WEAK INFEED**

## 2.4 Blocked Overreach (Some models only)

This scheme is only available on relays with four zones of protection, because a reverse-looking element is required to allow the sending of a blocking signal.

### 2.4.1 Scheme Operation

The fault must be in the region between the two relays (i.e. on the line section) if; The overreaching Zone 2 element operates and a reverse looking zone at the remote end has **not** operated. This can be seen in the diagram below;

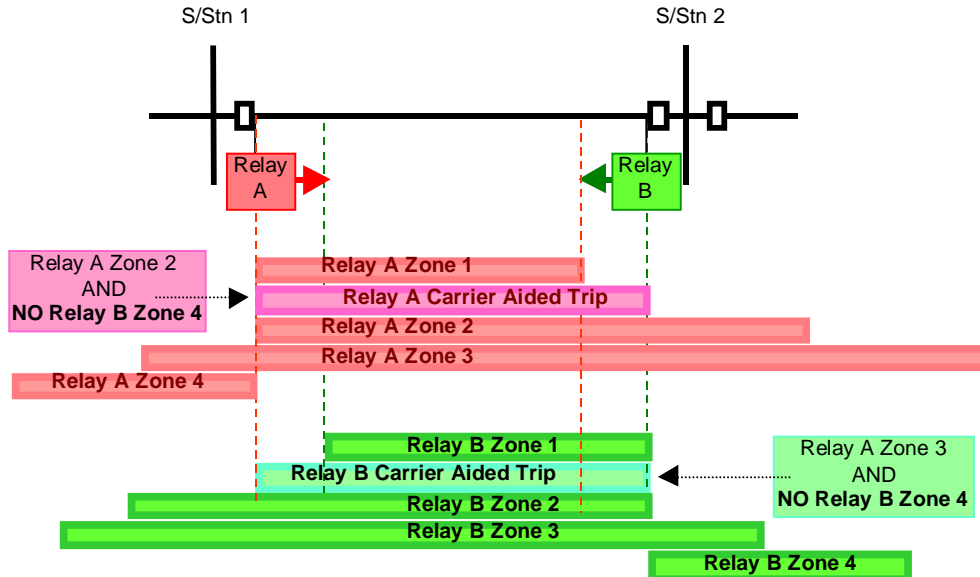

When the Zone 2 instantaneous element picks up, the relay waits for a “blocking signal” to be received. If no blocking signal is received during a set time delay (known as the Permissive Trip Time) the relay will carry out a “Carrier Aided Trip”. If, during this time delay, a blocking signal is received, the Zone 2 time delay will remain in place, and the relay will carry out a Zone 2 trip after the Zone 2 Time delay.

If the fault is in the last section of the line (i.e. outside the Zone 1 reach) the Zone 2 element will operate, but the remote end relay Zone 4 element will not see the fault. Thus, no blocking signal will be sent, and the relay will carry out a “Carrier Aided Trip” after the *Permissive Trip Time*.

Obviously when applying this scheme the reverse reach of the Zone 4 element must be further than the overreach of the remote end Zone 2 element.

Where the signalling equipment has an output which indicates that the signalling channel is out of service, this can be connected to a Status Input called *Carrier Recv Guard*. On energisation of this status input the relay will revert to a time stepped distance scheme.

The scheme also incorporates an *Unstabilise Relay* status input which can be used for intertripping. Energisation of this status input will prevent a Blocking signal send when a reverse fault is detected in Zone 4.

### 2.4.2 Settings

Distance Scheme	BOR
Permissive Trip Time	0..60000 (1ms)
SS Dropoff	0..60000 (1ms)
SR Dropoff	0..60000 (1ms)

Status Inputs: **BLOCK MODE INHIBIT, CARRIER RECV GUARD, UNSTABILISE RELAY**

Relay Outputs: N/A

## 2.5 Acceleration

### 2.5.1 Scheme Operation

This is similar to the Permissive Undereach scheme except for the fact that receipt of a permissive signal removes the time delay from the Zone 2 element instead of the Zone 3 Element. The scheme is shown in the diagram below;

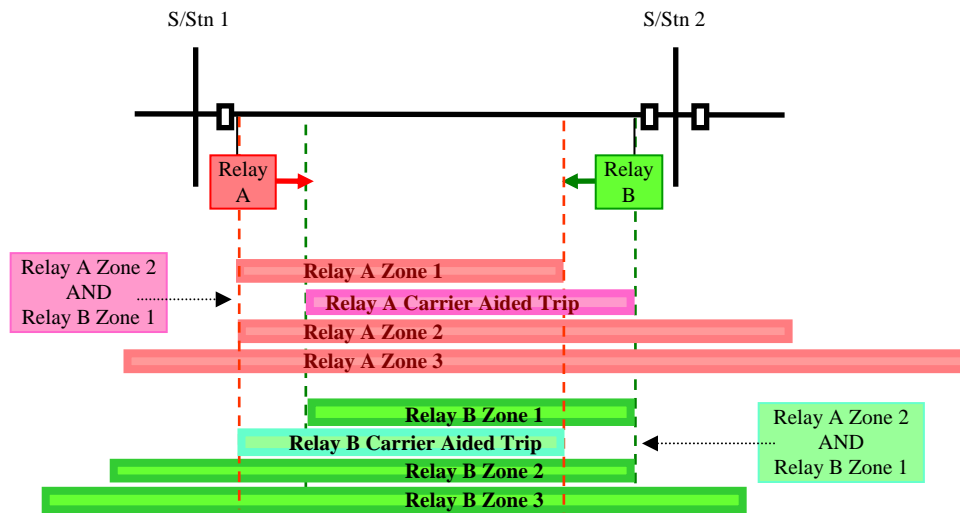

### 2.5.2 Settings

<i>Distance Scheme</i>	ACCELERATION
<i>SS Dropoff</i>	0..60000 (1ms)
<i>SR Dropoff</i>	0..60000 (1ms)

Status Inputs: **CARRIER RECV GUARD, SIGNAL RECEIVE 1**

Relay Outputs: **AIDED TRIP, SIGNAL SEND 1**